

# Tea Lux





Tea Lux



Le forme ed i volumi del TEA che già lo rendevano unico nel settore dell'arredo baer, con questa operazione di restyling, diventano esteticamente più attuali, in linea con le tendenze del moderno design che richiama all'uso di materiali moderni e tecnologici. § The shapes and volumes of TEA are unique in the bar furnishing sector and with this re-styling operation become more contemporary, aesthetically speaking, in line with current design trends that require the use of modern and technological materials. § Les formes et les volumes du TEA, qui le rendaient déjà unique dans le secteur de l'aménagement pour bars, avec cette opération de remise à neuf stylistique, deviennent esthétiquement plus actuelles, en accord avec les tendances du design moderne qui relance l'utilisation des matériaux modernes et technologiques. § Формы и объём ТЕА уже сделали её единственной в секторе мебели для бара и, благодаря изменениям дизайна, стали эстетически более актуальными, на уровне с течением современного дизайна, призывающий необходимость использования современных и технических материалов.



















L'uso dell'acciaio come elemento estetico e di altri materiali come il metacrilato colorato, riescono a dare un'impronta di gradevole impatto integrandosi perfettamente nel carattere dell'arredo. gli effetti della luce colorata sono una ulteriore innovazione e danno un tocco di eleganza all'estetica del banco. § The use of steel as an aesthetic element, and of other materials such as coloured methacrylate, offers a very pleasing impression, becoming perfectly integrated with the furnishing characteristics. The coloured light effects are a further innovation and give a touch of elegance to the bar counter. § L'utilisation de l'acier comme élément esthétique et d'autres matériaux comme le méthacrylate coloré, offre un impact agréable et s'intègre parfaitement au caractère de l'aménagement. Les effets de la lumière colorée sont une ultérieure innovation et donnent une touche d'élégance à l'esthétique du comptoir. § Использование стали в качестве декоративного элемента и других материалов, таких как цветной метакрил, оставляют приятное впечатление прекрасно вписываясь в характер мебели. Эффект цветного света - это одно из новшеств придающий элегантный стиль эстетике бара.





















La gamma dei pannelli è stata ampliata con altri laccati come il giallo lucido, il metallizzato opaco, il blu lucido o il crema ed altre estetiche come il nuovo pannello tipo ciliegio opaco, o l'effetto luna blu lucido oppure l'effetto radica opaco. § The panel range has been extended to other lacquered options such as glossy yellow, metallic mat, glossy blue or cream and other options such as the new mat cherry-effect panel, or the glossy blue moon-effect or a mat briar-root effect. § La gamme des panneaux a été amplifiée avec d'autres panneaux laqués comme le jaune brillant, le métallisé mat, le bleu brillant ou le crème et d'autres esthétiques comme le nouveau panneau type merisier mat, ou l'effet lune bleue brillant ou l'effet bruyère mat. § Гамма панелей расширилась другими лакированными тонами: глянцево-жёлтый, матово-металлический, глянцево-синий или кремовый и другие, как например новая панель матовая черешня или эффект мотовой радики.













DISEGNI TECNICI

BANCO BAR H.1120

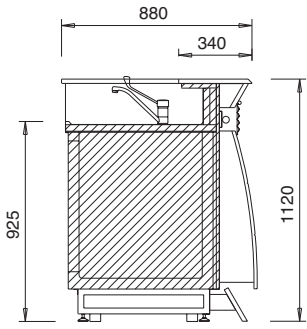

BANCO H.945

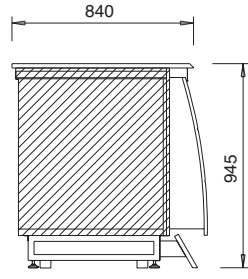

VETRINA ALTA

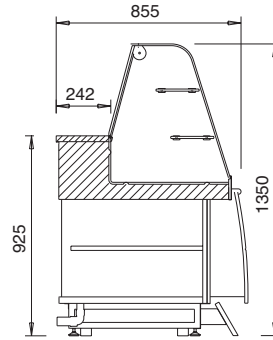

VETRINA BASSA

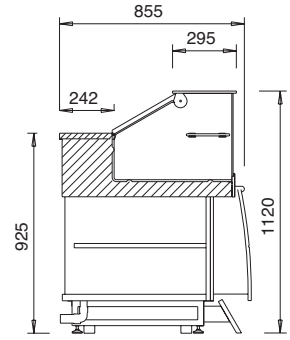

125 ANGOLO A2-903MAXI

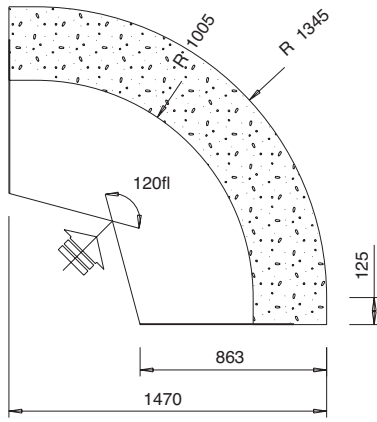

ANGOLO A1-903MAXI

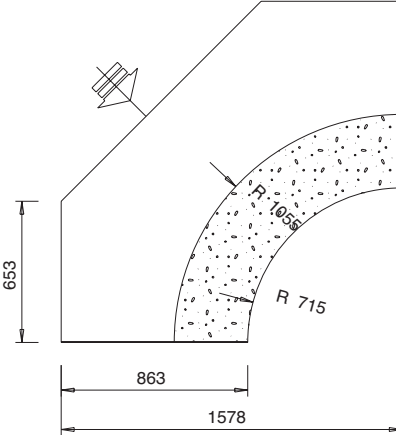

VETRINA CURVA

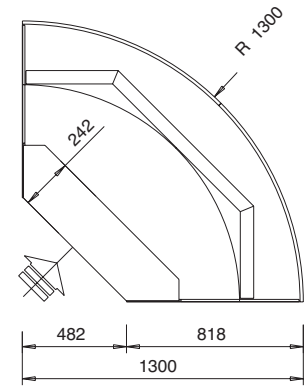

ANGOLO A1-903

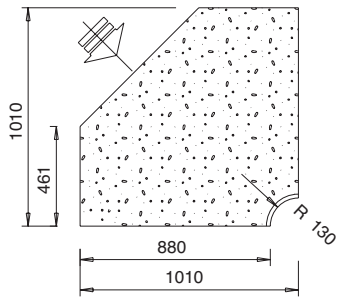

ANGOLO A2-903

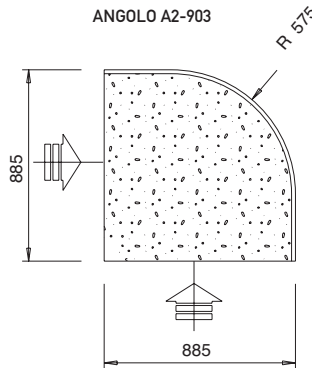

ANGOLO A1-453

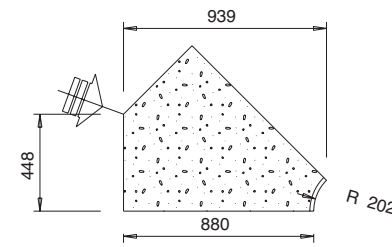

ANGOLO A2-453

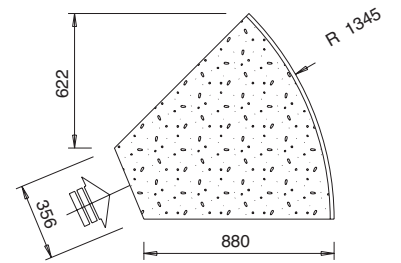

FIANCO TERMINALE

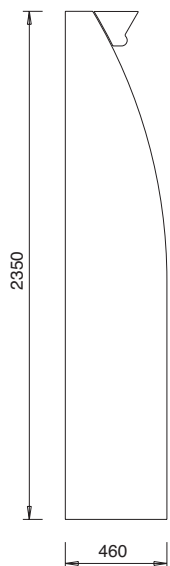

FIANCO TERMINALE

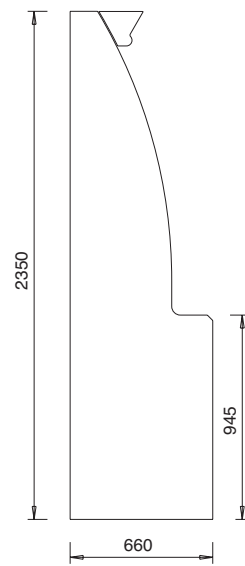

FIANCO TERMINALE

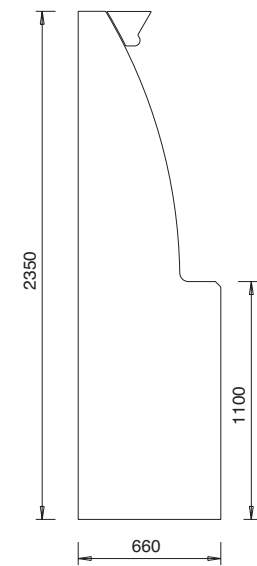

RETRO PER BOTTIGLIE

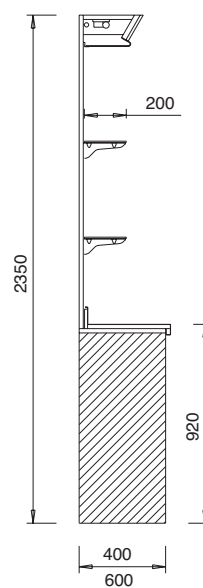

RETRO PER M.CAFFE

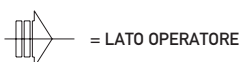
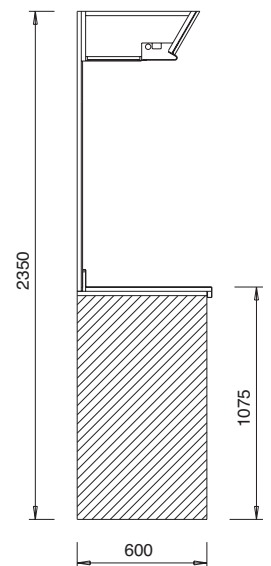



Linea ELITE - Collezione TEA LUX

GRIGLIA DELLE COMBINAZIONI

CLIENTE

DATA

RIF

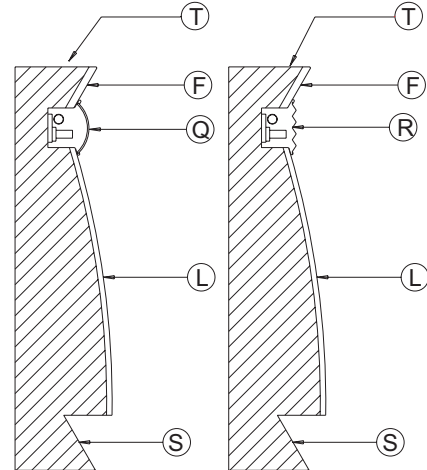
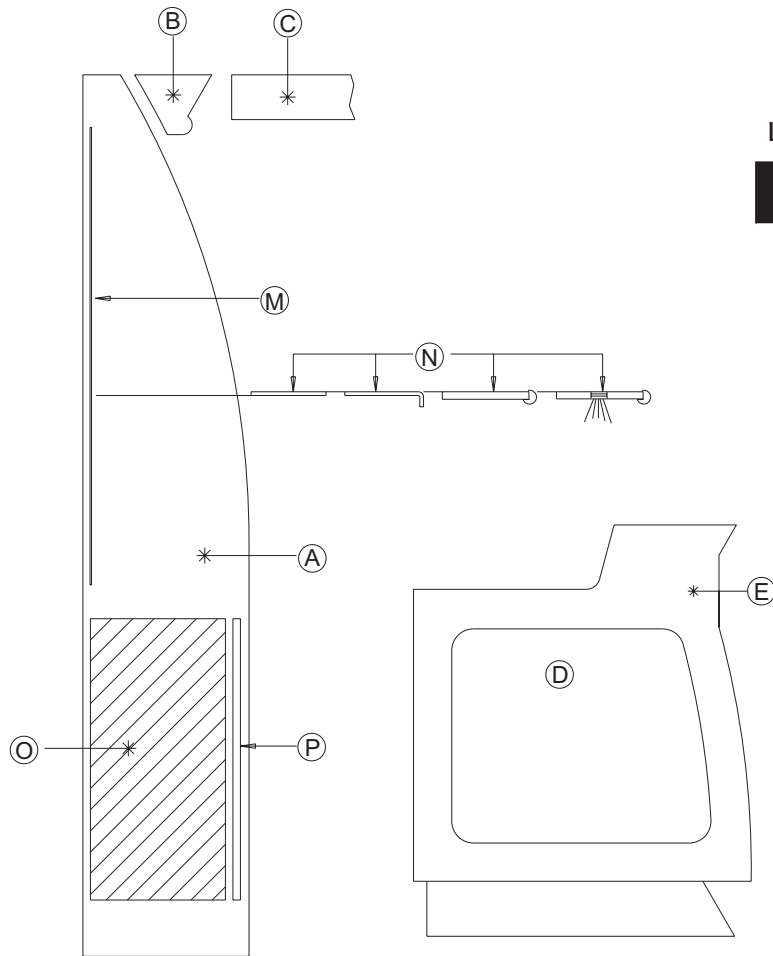

|   |  |  |  |  | NUOVO CILEGIO<br>OPACO | EFFETTO LUNA<br>BLU LUCIDO | RADICA<br>OPACO | METALLIZZATO<br>OPACO | GIALLO<br>BRILLANTE | BLU<br>LUCIDO | PANNA<br>LUCIDO | METACRILATO<br>BLU | METACRILATO<br>MARRONE | METACRILATO<br>ACQUA MARINA | ACCIAIO<br>INOX |  |  | LAMINATO<br>GRIGIO |  | SPECCHIO<br>BIANCO | MENSOLA<br>CRISTALLO | M. CRISTALLO<br>CURVATA | MENSOLA<br>LEGNO | MENSOLA LEGNO<br>ILLUMINATA | GRANITO-MARMO<br>AGGLOMERATO |  |
|---|--|--|--|--|------------------------|----------------------------|-----------------|-----------------------|---------------------|---------------|-----------------|--------------------|------------------------|-----------------------------|-----------------|--|--|--------------------|--|--------------------|----------------------|-------------------------|------------------|-----------------------------|------------------------------|--|
| A |  |  |  |  |                        |                            |                 |                       |                     |               |                 |                    |                        |                             |                 |  |  |                    |  |                    |                      |                         |                  |                             |                              |  |
| B |  |  |  |  |                        |                            |                 |                       |                     |               |                 |                    |                        |                             |                 |  |  |                    |  |                    |                      |                         |                  |                             |                              |  |
| C |  |  |  |  |                        |                            |                 |                       |                     |               |                 |                    |                        |                             |                 |  |  |                    |  |                    |                      |                         |                  |                             |                              |  |
| D |  |  |  |  |                        |                            |                 |                       |                     |               |                 |                    |                        |                             |                 |  |  |                    |  |                    |                      |                         |                  |                             |                              |  |
| E |  |  |  |  |                        |                            |                 |                       |                     |               |                 |                    |                        |                             |                 |  |  |                    |  |                    |                      |                         |                  |                             |                              |  |
| F |  |  |  |  |                        |                            |                 |                       |                     |               |                 |                    |                        |                             |                 |  |  |                    |  |                    |                      |                         |                  |                             |                              |  |
| G |  |  |  |  |                        |                            |                 |                       |                     |               |                 |                    |                        |                             |                 |  |  |                    |  |                    |                      |                         |                  |                             |                              |  |
| H |  |  |  |  |                        |                            |                 |                       |                     |               |                 |                    |                        |                             |                 |  |  |                    |  |                    |                      |                         |                  |                             |                              |  |
| I |  |  |  |  |                        |                            |                 |                       |                     |               |                 |                    |                        |                             |                 |  |  |                    |  |                    |                      |                         |                  |                             |                              |  |
| L |  |  |  |  |                        |                            |                 |                       |                     |               |                 |                    |                        |                             |                 |  |  |                    |  |                    |                      |                         |                  |                             |                              |  |
| M |  |  |  |  |                        |                            |                 |                       |                     |               |                 |                    |                        |                             |                 |  |  |                    |  |                    |                      |                         |                  |                             |                              |  |
| N |  |  |  |  |                        |                            |                 |                       |                     |               |                 |                    |                        |                             |                 |  |  |                    |  |                    |                      |                         |                  |                             |                              |  |
| O |  |  |  |  |                        |                            |                 |                       |                     |               |                 |                    |                        |                             |                 |  |  |                    |  |                    |                      |                         |                  |                             |                              |  |
| P |  |  |  |  |                        |                            |                 |                       |                     |               |                 |                    |                        |                             |                 |  |  |                    |  |                    |                      |                         |                  |                             |                              |  |
| Q |  |  |  |  |                        |                            |                 |                       |                     |               |                 |                    |                        |                             |                 |  |  |                    |  |                    |                      |                         |                  |                             |                              |  |
| R |  |  |  |  |                        |                            |                 |                       |                     |               |                 |                    |                        |                             |                 |  |  |                    |  |                    |                      |                         |                  |                             |                              |  |
| S |  |  |  |  |                        |                            |                 |                       |                     |               |                 |                    |                        |                             |                 |  |  |                    |  |                    |                      |                         |                  |                             |                              |  |
| T |  |  |  |  |                        |                            |                 |                       |                     |               |                 |                    |                        |                             |                 |  |  |                    |  |                    |                      |                         |                  |                             |                              |  |

A = FIANCO TAMP. RETRO \* B = TAMP. CIELINO \* C = CIELINO \* D = TAMP.FIANCO TERM.  
 E = FIANCO TERM. \* F = FASCIONE  
 L = PANNELLO \* M = SCHIENALE \* N = MENSOLA \* O = BASE RETRO \* P = ANTINA  
 Q = EL. ESTETICO ILLUMINATO IN METACRILATO \* R = EL. ESTETICO ILLUMINATO IN ACCIAIO  
 S = ZOCCOLO \* T = PIANI LAVORO

tea/94-127a





La qualità del prodotto si basa principalmente sull'uso di ottimi materiali in tema di:  
**ISOLAMENTO:**  
per la coibentazione dei pannelli isolanti vengono usati componenti poliuretanici senza CFC.  
**REFRIGERAZIONE:**  
tutti gli impianti, in linea con le recenti normative.

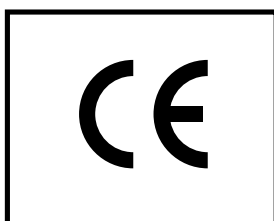

Tutti i prodotti sono conformi ai requisiti di sicurezza previsti dalle direttive:  
89/392 EEC - 91/368 EEC  
93/44 EEC - 93/68 EEC

DESIGN

**GARBUGLI/VINCENZETTI RESTYLING BY ARTIC 1999**

PROGETTO GRAFICO E IMPAGINAZIONE

**RING**

FOTO

**33 MULTIMEDIA STUDIO**

ART BUYER

**CLAUDIA UGUCCIONI**

TRADUZIONI

**IT BÜRO**

DISEGNI TECNICI

**UFFICIO TECNICO ARTIC**

STAMPA

**STAMPA NOVA**

FINITO DI STAMPARE NEL MARZO 2003

**MARCHIO E PRODOTTI BREVETTATI**





ARTIC

Divisione CLABOGROUP S.p.A.

ZIPA - Viale dell'Industria

60035 Jesi (Ancona) Italy

tel. +39 0731 61531

fax +39 0721 499901

stabilimento Montelabbate

Via Apsa, 18

[www.clabogroup.com](http://www.clabogroup.com)

[info@clabogroup.com](mailto:info@clabogroup.com)